

Performance

Lifting height — on stabilisers	17500.0 mm
Lifting height — on tyres	16200.0 mm
Rated capacity	4000 kg
Capacity (at max. height on stabilisers)	2500 kg
Capacity (at max. height on tyres)	1000 kg
Capacity (at max. reach on stabilisers)	560 kg
Capacity (at max. reach on tyres)	0 kg
Max. reach on stabilisers	13700.0 mm
Max. reach on tyres	12800.0 mm
Crowding force	4900 daN

Weights

Weight (unladen)	10790 kg
------------------	----------

Traction

Standard tyres	400/80x24
Low speed (forward/reverse)	8.5 km/h
High speed (forward/reverse)	30.0 km/h
Driving modes	Direct drive / soft drive

Drive System

Main drive	Hydrostatic motor
Transmission	Hydrostatic with electronic regulation

Engine

Make / Model	DEUTZ / TCD 3.6 L4
Fuel	Diesel
Cooling	Liquid
Rated power (ISO 14396) at 2300 RPM	74.4 kW
Maximum torque at 1600 RPM	410.0 Nm
Number of cylinders	4
Displacement	3.62 L

Hydraulic System

Pump type	Gear pump with LS valve
Combined pump capacity	100.00 L/min

Cycle Times

Lift time - no load	12.8 s
Lower time - no load	8.4 s
Telescope in time at max. reach - no load	20.3 s
Telescope in time at max. height - no load	17.7 s
Telescope out time at max. reach - no load	29.0 s
Telescope out time at max. height - no load	29.0 s

Brakes

Engine braking	Hydrostatic
Parking and emergency brake	Negative brake with hydraulic command

Fluid Capacities

Axles and reduction gears front / rear	9.1/9.1 L
Fuel tank	145.00 L
Hydraulic reservoir [HYDRAULIC]	76.00 L

Standard Features

Aggravating Movements Arrester (AMA)	Right and left side mirrors
Hydrostatic transmission	Two way hydraulic supply at the end of the boom
ROPS/FOPS operator cab	Mudguards
Heating, demisting and ventilation	Turbo-charged engine - Deutz 3B
Front and rear washer/wipers	Narrow hook-up for mounting of the equipment
Suspension seat	Mechanical lock of the equipment
Road lights	Four 400/80x24 tyres
Turn signals	Transmission lock override

Environmental

Sound pressure level (LpA)	79 dB(A)
Level of acoustic power (LWA)	106 dB(A)
Whole body vibration (ISO 2631-1)	0.29 ms ⁻²

Load Charts

With forks and standard 400/80x24 tyres, on stabilisers

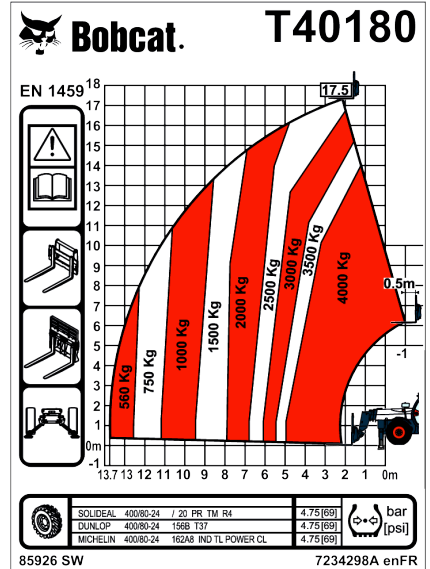

Complies with stability test EN1459 Annex B

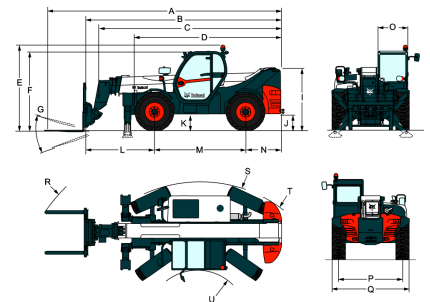
Dimensions

(-) 16°	(M) 2850.0 mm
(-) 109°	(O) 930.0 mm
(A) 7425.0 mm	(P) 1992.0 mm
(B) 6164.0 mm	(Q) 2394.0 mm
(E) 2670.0 mm	(R) 5822.0 mm
(F) 2476.0 mm	(S) 3782.0 mm
(G) 124°	(U) 1761.0 mm
(J) 500.0 mm	

Options

Air conditioning	Man platform predisposition
Air suspension seat	Multifunctional remote control
Auxiliary line on boom	No forward/reverse control on joystick
with ACD and electric connectors	Pintle tow hitch
Back up alarm	Radio ready
Basic tow hitch	Rear flat mirror
Boom stop	Roof window wiper
Carriage with hydraulic attachment lock	Rotating beacon
Cold start	Sun visor
Custom colour	Support for registration plate
Cyclonic air prefilter	Windscreen grill
Double right rear view mirror	Work light on boom
Drawbar coupler tow hitch	Wheel wedge
Fan inverter	Winch ready
Fire extinguisher	
Lockable fuel cap	